

DISCONTINUATION INFORMATION

PHASE V LAST CALL

BPC, SPC powder (coating) systems

Upgrade to the latest
powder coating
technology



Applies to the following powder systems:

BPC, SPC equipped with:

- EATON MOELLER PLC Easy
- High voltage controls Art. No. 39153



WHY UPGRADE?

As many electronic components used in older Frei AG systems are getting phased-out by suppliers, the need to adapt electrical systems to accommodate new equivalent replacements is ever increasing. This is the best opportunity to not only restore old functionality but to upgrade to the latest technologies.

CURRENT PHASE-OUT STATUS

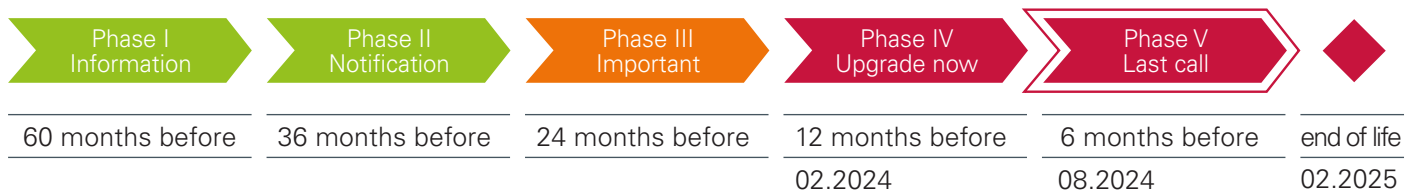

PHASE V: WHAT DOES THIS MEAN FOR YOU?

- Repairs can no longer be guaranteed
- Order now: Upgrade or replacement to the latest coating technology
- BPC, SPC will be phased-out completely by 02.2025

Major downtimes of production line are imminent!

ADVANTAGES OF THE NEW UPGRADE

Since the PLC control and the high-voltage card are no longer available on the BPC and LPC powder systems, an upgrade is required. At the same time, these systems are being brought up to a level that allows production 24/7.

- New PLC (controller) and HMI (touch panel):
 - Recipes: Save your individual settings
 - Graphical status display of all components
 - Error logs with text and image
 - Efficiency evaluation
 - Maintenance recommendations
 - Help section with information and movies
- New electrical cabinet base plate with new components
- Newest high voltage system HVM-ETH, controlled over HMI
- Spray current measuring adjustable on HMI
- Proportional valves to adjust powder quantity on HMI
- New frequency controlled vacuum blower with integrated safety filter
- Conversion to two filters with simplified automatic filter cleaning and more vacuum power
- Screening unit with waste powder container and compensation filter
- FPF fresh powder feeder to feed fresh powder fully automatically to the coating container
- Ejector to boost over-spray suction on powder arm
- Closing cylinder on coating injector to clean the powder feeding tubes on every coating stop
- INSIGHTS ready



OPTIONS AVAILABLE

- Various monitoring systems available
- New powder arm

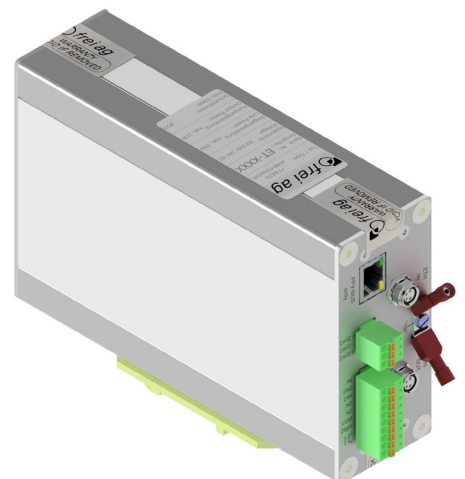

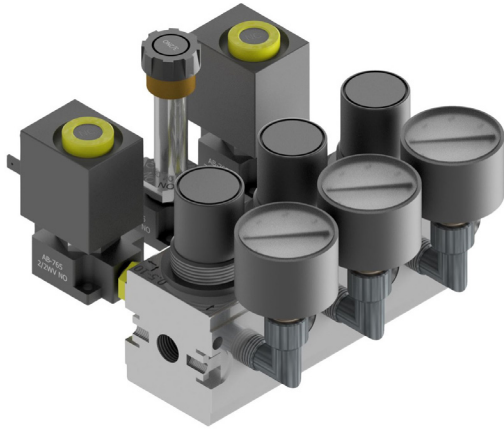

NEW

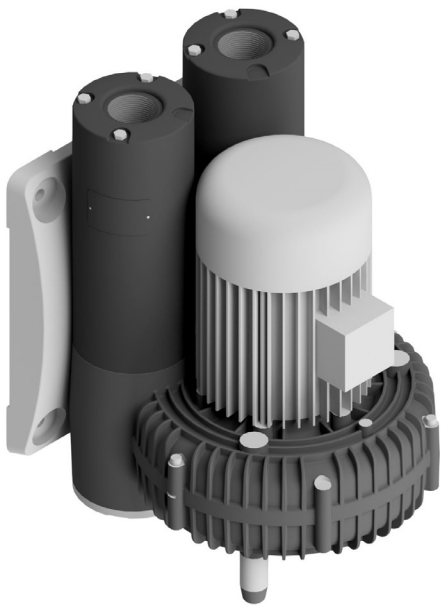

NEW



NEW



Filling by hand

Automatic filling from fresh powder drum



NEW

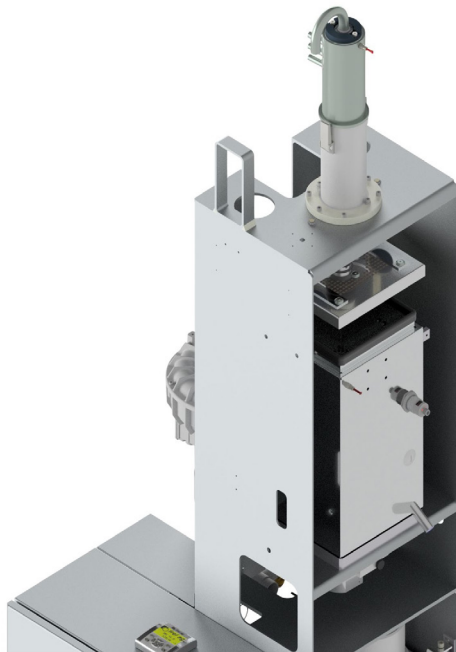

NEW

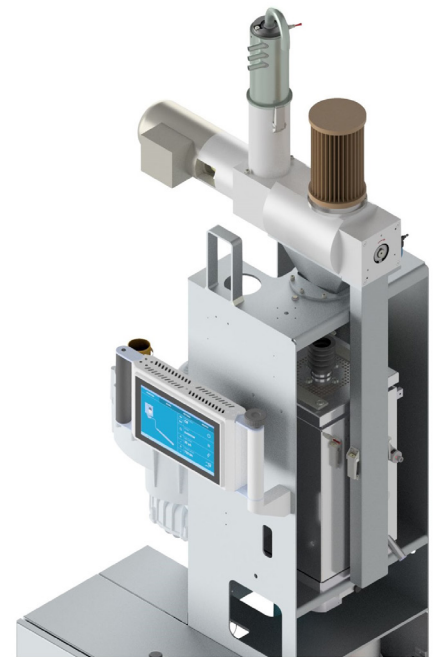

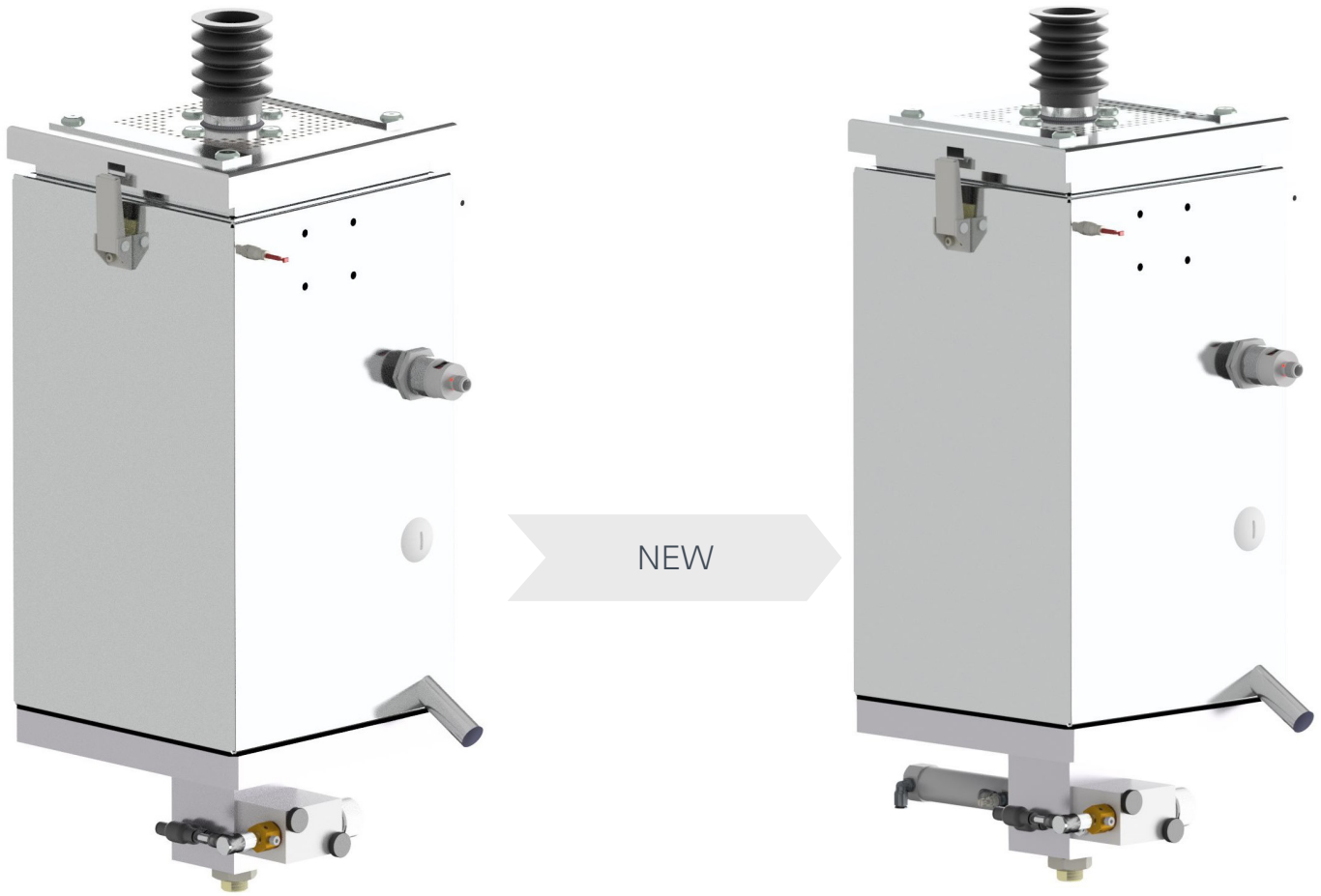

NEXT STEP

Please contact your sales contact or send an email to info.frei-ag@soudronic.com. We will be happy to work out a quotation for the conversion for your equipment.