



FBB ECO SHORT CURRENT BUS BAR

COMBINE TRIED AND TESTED FBB WITH THE LATEST SOUCAN TECHNOLOGY TO SLASH ENERGY COSTS AND OPTIMIZE RUNNING.

Simply optimizing current conduction can cut your energy costs by as much as 30%! Reduced thermal radiation in the rounding zone provides huge benefits: it not only opens up scope for cutting energy costs but also substantially increases operating reliability.

CONVERSIONS AND RETROFITS

Basically, all FBB 400 to FBB 5500 welders can be converted to ECO (short current bus bar). Machines can be converted either on site or in Soudronic's own workshops.

Other useful conversions worth considering are: UNICONTROL, frequency-controlled drives, wire components, air and water installations, ARS, DISCON, UNITOOL, protective covers.

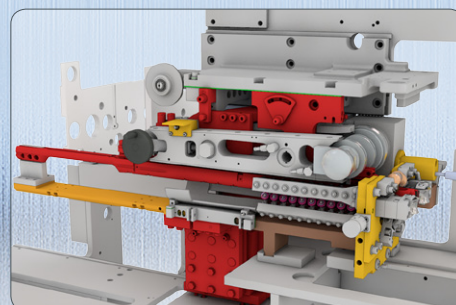

Overview of assemblies

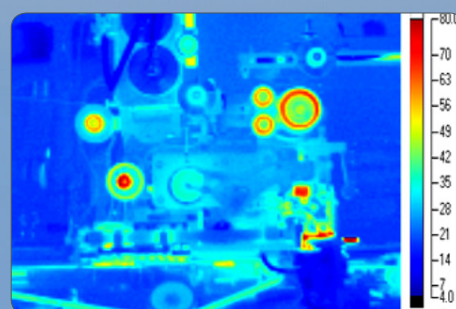
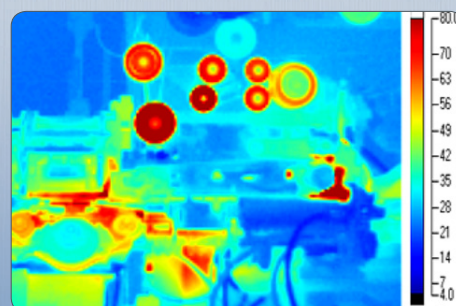

Example of FBB 5501 and T3 ECO
Comparison of thermal radiation of an old machine with optimized current conduction

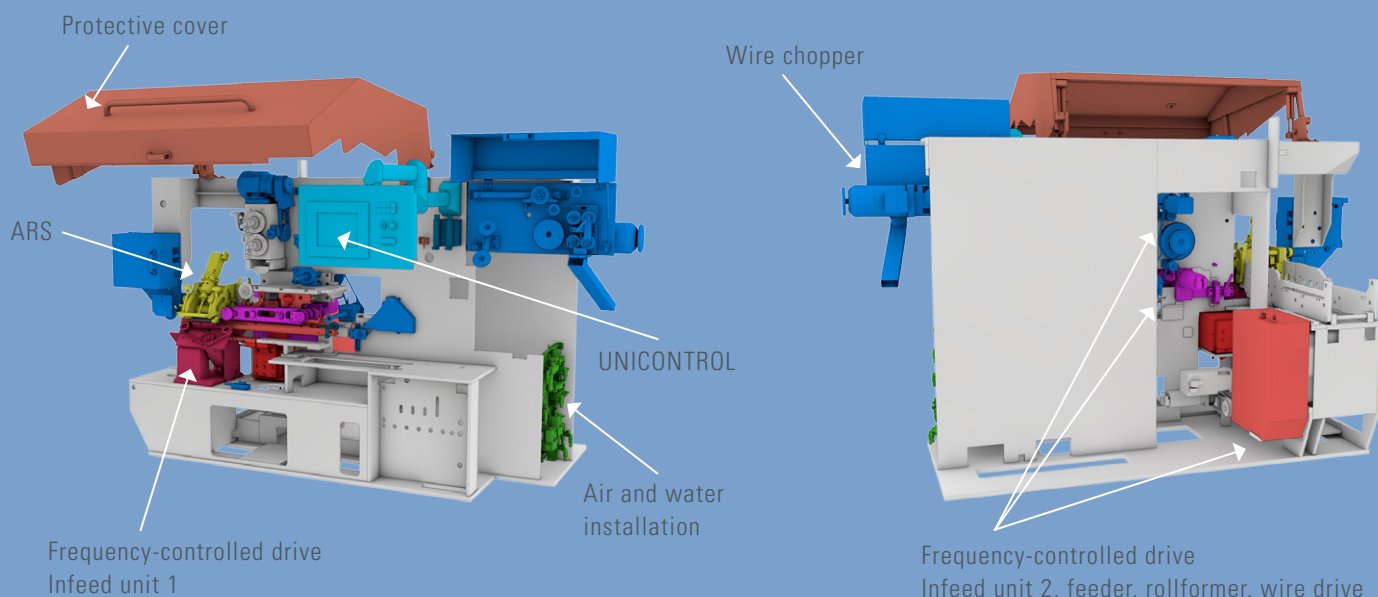

THE CONVERSION IN PICTURES

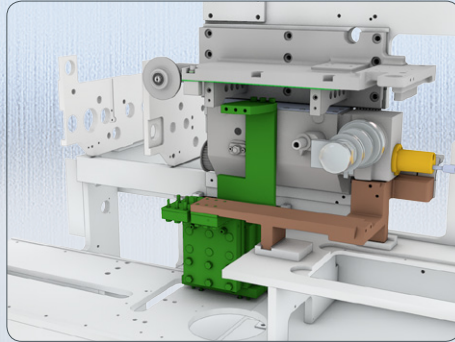

Current bus bar

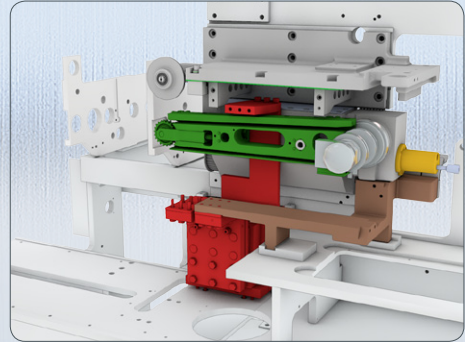

Chain guide on machine side

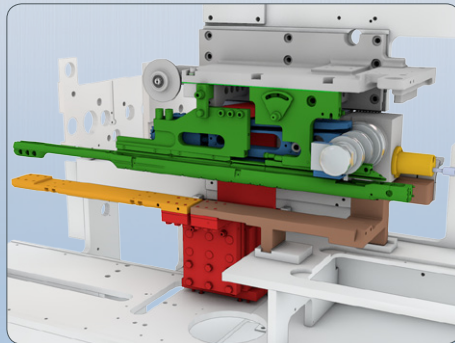

Lower arm

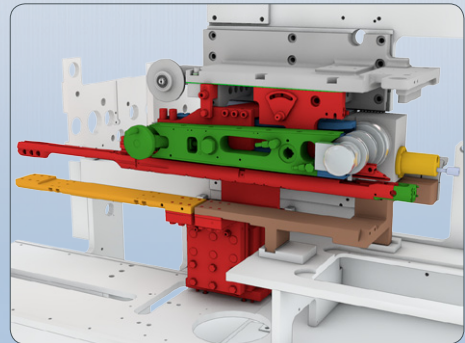

Chain guide on operator side

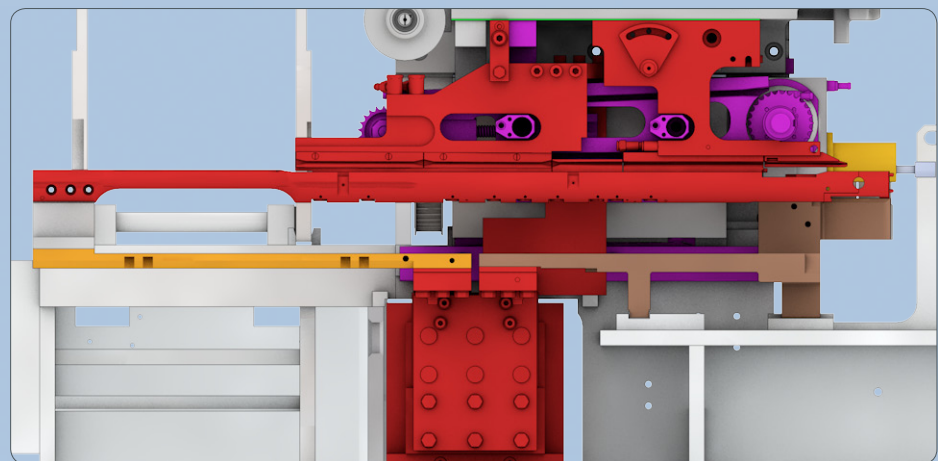

Technology that keeps you ahead

Soudronic

Soudronic AG Industriestrasse 35 CH-8962 Bergdietikon +41 44 743 66 66 info@soudronic.com www.soudronic.com