



MONITOR TAP SOUCAN

New, more robust, silicone-free design.

The monitor tap has been redesigned comprehensively. Previously, the cables were inserted in cable guiding grooves, which were sealed with silicone.



old monitor tap

new monitor tap

In addition, the cable contact point was very exposed and susceptible to damage from crashes and mishandling. Now all components are safely accommodated in a robust housing made with state-of-the-art 3d printing technology. The use of silicone, which can cause problems in the filled product, has been eliminated.

The contact segment remains unchanged and will be used in all SOUCAN welders. It can be easily turned so that both sides can be used. Replacement is carried out by using a conventional screwdriver and open-end wrench.

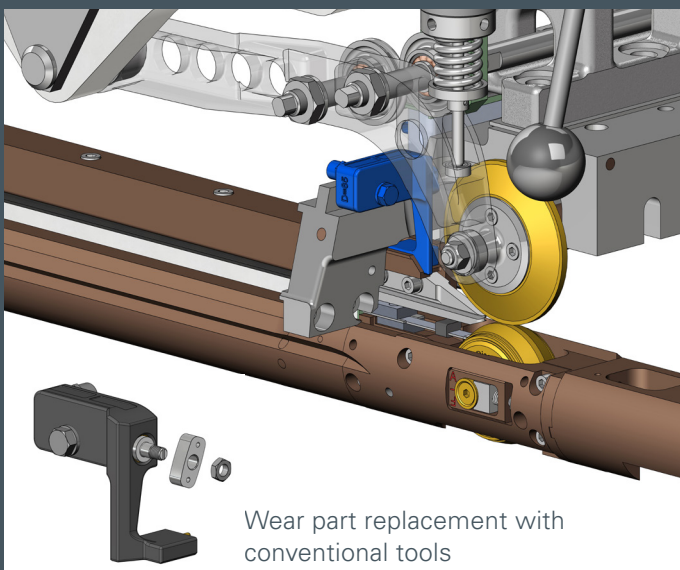

Wear part replacement with conventional tools

CUSTOMER BENEFITS

- Less prone to damage due to protected cable routing
- Silicone-free
- Wear part replacement with conventional tools

RETROFITTING

- All SOUCAN machines
- The carbide contact segment (wear part) remains unchanged