



TANDEM OUTSIDE SPRAY SYSTEM FOR HIGH-END PRODUCTION REQUIREMENTS

The tandem OSS was developed with a view to improving weld seam quality. Having two OSS units increases the thickness of the lacquer layer and protects the weld seam effectively against corrosion.

Soudronic launched its new OSS technology in 2013, thus establishing new benchmarks for outside seam lacquering in terms of application quality, production reliability and user friendliness. Contactless application was no novelty in 2013. However, the uniquely low pressure makes it possible to apply lacquer precisely, without overspraying. OSS technology offers significant advantages that have contributed to its success.



Certain market regions and segments require increased protection against corrosion. Regardless of the application process used, however, the maximum thickness of a lacquer layer is limited. Double

application seems logical, but is not possible with roller systems. Now, OSS technology enables increased layer thickness thanks to double coating. It also allows you to give the middle of the weld an additional layer of lacquer on its own.

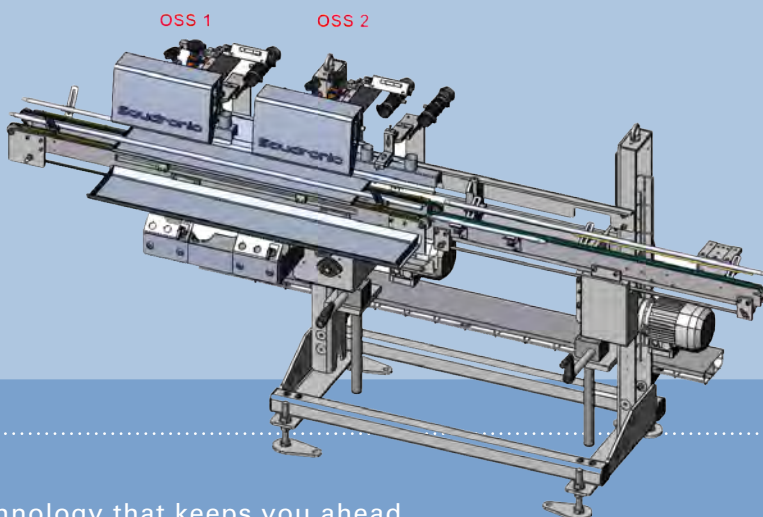

The tandem OSS system is compact. It can be integrated into an existing production environment with little effort, and is ready for operation straight away. The integrated lacquer sensor system makes the production process especially secure.

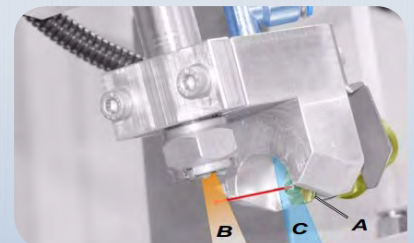

A: Sensor / B: Lacquer film / C: Cleaning air

ADVANTAGES

- Higher protection from corrosion on the outside seam
- Variable partial lacquer coating
- Low space requirement

AVAILABILITY

Retrofitting or conversion to the tandem OSS is possible.

The standard LARC must be extended by 500 mm (welding machine – curing unit).

Technology that keeps you ahead

Soudronic