

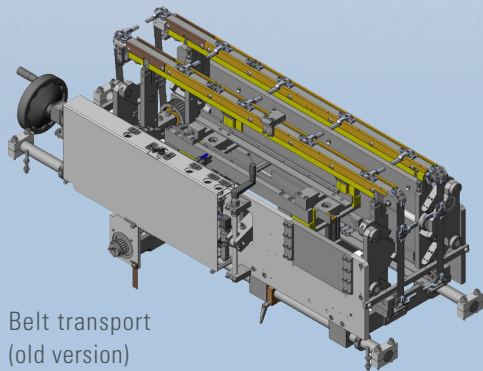

## MAINTENANCE-FREE CHAIN (CONVEYOR 1 / SOUCAN 600)

**The maintenance-free chain requires no lubrication.**

In the past, some customers have preferred a belt conveyor because, unlike the chain conveyor, it needed no active lubrication. However, the belt conveyor had two disadvantages: it was not possible to use the third feed system (undersquare can formats); and not all the chain conveyor's pitches were available. With smaller canbody diameters, users often complained about wear and tear on the belt guides. Furthermore, replacement of the conveyor belt was a complicated job because it meant disconnecting the drive shafts. The maintenance-free chain not only requires no lubrication but is also easily assembled.



Belt transport  
(old version)

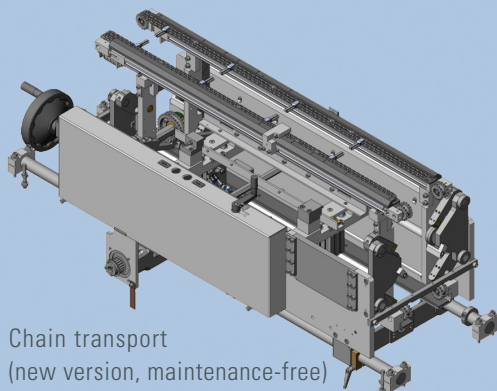

Chain transport  
(new version, maintenance-free)

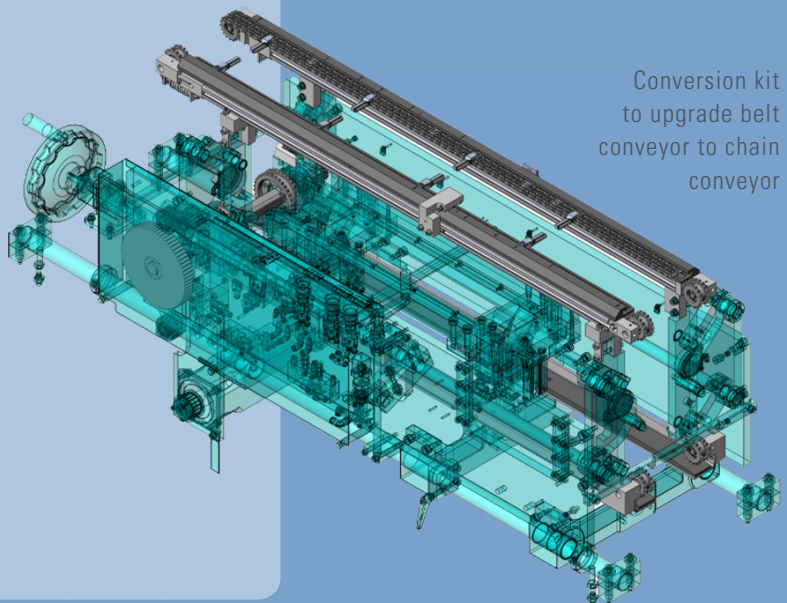

Conversion kit  
to upgrade belt  
conveyor to chain  
conveyor

## ADVANTAGES

- Lubrication no longer required
- A third feed system can be added
- All the pitches of the previous chain are available
- No non-ferrous metals in the chain guide (wear)
- The chain guide no longer needs to be cooled (leakage)
- Chain dogs made of CrNi steel (heating through electric field is extremely low)
- Attractive design

## RETROFITTING

- Chain belt conveyors on older machine types can be retrofitted with the maintenance-free chain on request.