



## WIRE-BREAK SAFETY DEVICE FOR DSA

The wire-break safety device on the DSA prevents welding machines from making emergency stops.

### ADVANTAGES

- no emergency stops on the welding machine in the event of problems with unrolling wire
- no loss of can bodies (simple line stop)
- increased efficiency
- no need to remove defective can bodies from the welding machine
- higher efficiency
- simple operation



Suitable for  
all machine types  
with DSA

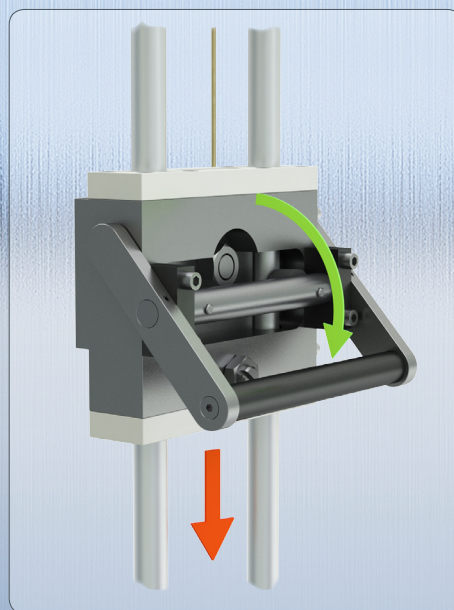

Releasing the upper lock-in position

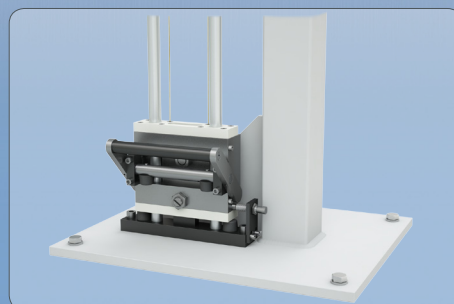

Lower lock-in position



Simple wire guide on pulley

Technology that keeps you ahead

Soudronic AG Industriestrasse 35 CH-8962 Bergdietikon +41 44 743 66 66 info@soudronic.com [www.soudronic.com](http://www.soudronic.com)

# Soudronic